



**ZH LED Control System**



# ZH-Z28L

## 4K Two-in-one Video Processor

### Product Specification





# Product Specification

## ZH-Z28L

### (4K Video Processor)

#### I. Product Introduction:

The ZH-Z28L 4K 2-in-1 video processor is a product meticulously crafted by ZH to facilitate the convenient installation of large LED displays. It supports inputs from high-definition sources (such as HDMI and DP) with up to eight windows capable of arbitrary roaming and positioning. Capable of receiving high-definition digital signals up to 4096×2160@60Hz, it provides 28PCS Gigabit Ethernet outputs; a single unit can drive a large display with a maximum width of 16,384 pixels or a maximum height of 4,320 pixels. Featuring a brand-new communication architecture, it delivers high refresh rates, high brightness, and an advanced grayscale scanning engine with nanosecond-level synchronization. It maintains smooth communication even under adverse conditions, allowing users to experience a more colorful and brilliant LED world.

#### II. Functional Features:

1. Extensive input interfaces: includes 7cs HDMI 1.4 ports and 1pcs HDMI 2.0/DP 1.2 port;
2. Input resolution: supports up to 4096×2160@60Hz and allows for custom resolution settings;
3. Maximum load capacity: 18.2 million pixels, max width of 16,384 pixels, max height of 4,320pixels;
4. Supports seamless switching between video sources and allows for the stitching and scaling of input images based on display resolution.
5. Supports arbitrary roaming across 8 display windows;
6. Supports audio input and output;
7. Supports brightness and color temperature adjustment;
8. Supports high grayscale at low brightness;
9. Supports integration with central control systems via standard Ethernet ports;
10. 28pcs Gigabit Ethernet outputs, supporting arbitrary splicing (vertical/horizontal);
11. Supports hot backup: hot backup between two ports in the same group and multi-card hot backup;
12. Compatible with the full range of AVIC receiving cards, multifunction cards, and fiber optic transceivers;

#### III. Topology Diagram:



# ZH LED Display Control System

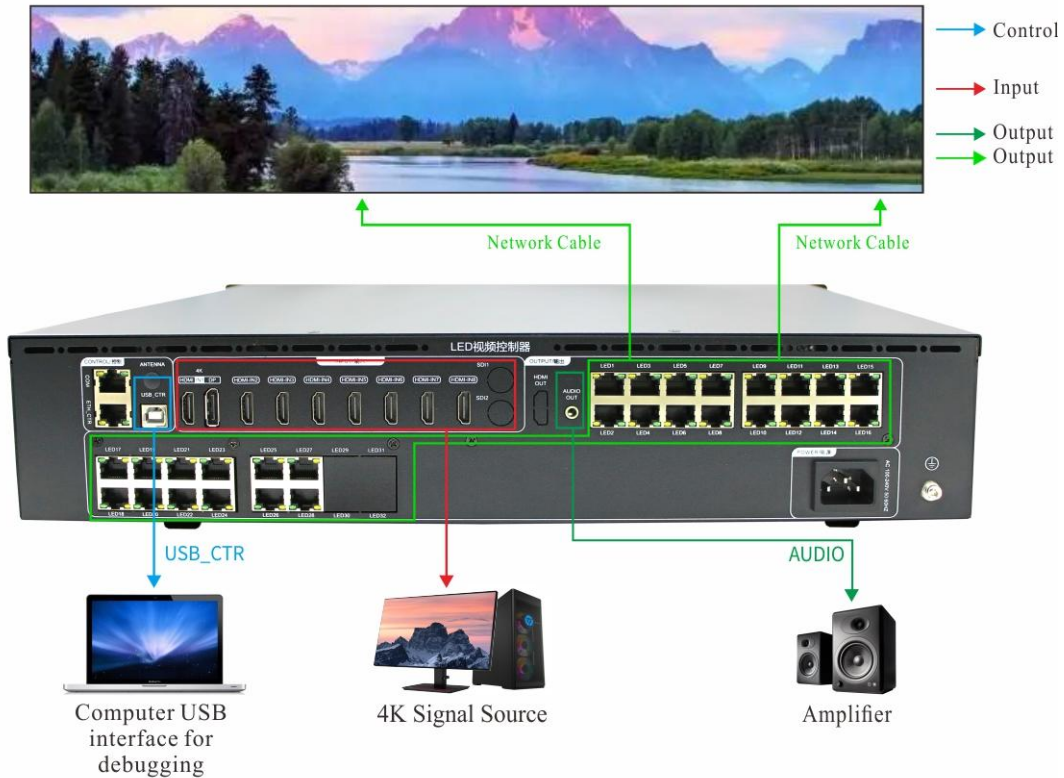

## IV. Hardware Introduction:

### The Front Panel

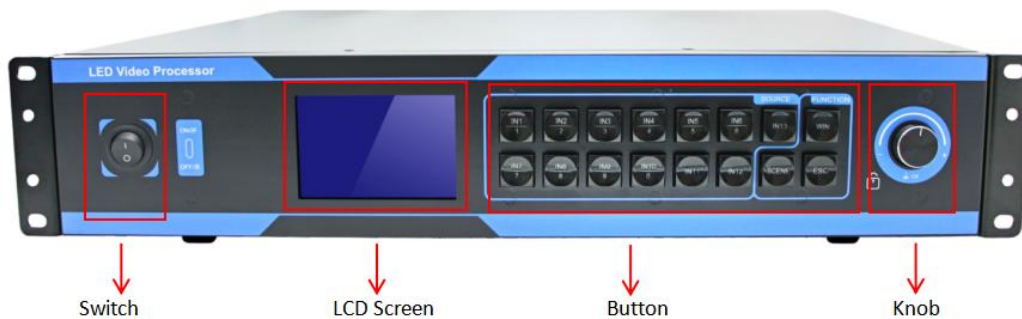

<b>Switch</b>	The power switch
<b>LCD</b>	Show the device status and operation interface
<b>Knob</b>	Pressing: To enter or confirm; Rotation: To move the cursor or modify parameters

Button Part Manual			
IN1/1	4K Signal HDMI or DP 1 / Digital 1	IN7/7	IN 7/Digital 7
IN2/2	IN 2/Digital 2	IN8/8	IN 8/Digital 8
IN3/3	IN 3/Digital 3	IN9/9	IN 9/Digital 9



# ZH LED Display Control System

IN4/4	IN 4/Digital 4	IN10/0	IN 10/Digital 0
IN4/5	IN 5/Digital 5	IN11	IN 11
IN6/6	IN 6/Digital 6	IN12	IN 12
IN13	IN 13	SCENE	Scene List
WIN	Windows key	ESC	Back (long press to lock/unlock)

## The Back Panel

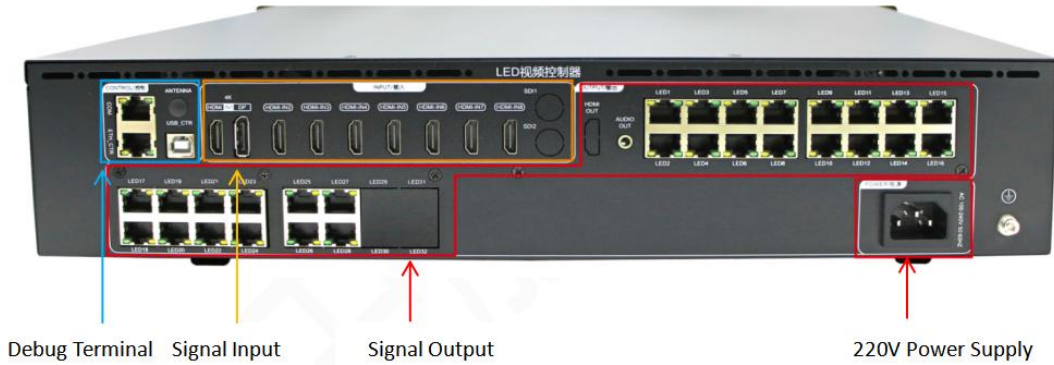

## Input:

CONFIG		INPUT		OUTPUT	
COM	Central control serial port integration	HDMI IN 1 DP	1-channel 4K signal (HDMI or DP)	LED*32	Output Network Ports 1-28
ETH_CTR	Central control network interface	IN2	HDMI Port 2	AUDIO_OUT	Audio Output
ANTENNA	Reserved interface	IN3	HDMI Port 3	HDMI OUT	Reserved preview/monitoring output
USB_CTR	Equipment debugging interface	IN4	HDMI Port 4		
		IN5	HDMI Port 5		
		IN6	HDMI Port 6		
		IN7	HDMI Port 7		
		IN8	HDMI Port 8		
		SDI1	Reserve the first SDI signal channel.		
		SDI2	Reserve the second SDI signal channel.		

Port	Quantity	Resolution Specification
HDMI 2.0	1	Compliant with EIA/CEA-861 and HDMI 2.0 standards; supports HDCP 2.2.
DP	1	Compliant with the DP 1.2 standard; supports HDCP 1.3.
HDMI 1.4	7	Compliant with the EIA/CEA-861 and HDMI 1.4 standards; supports HDMI



# ZH LED Display Control System

		audio input and output.
SDI	2	Supports 3G-SDI signal formats.

## Output:

Port	Quantity	Resolution
LED	28	Standard Gigabit Ethernet port, support ZH V5 all types of receiving cards, support arbitrary splicing up and down or left and right
AUDIO_OUT	1	3.5mm standard audio output port
HDMI OUT	1	EIA/CEA-861

## Chassis parameters:

Power Input	AC 100~240V, 50/60Hz, not more than 1A
Power	≤100W
Temperature	-20~45°C
Size	482.5*381.45*88.9(mm, L*W*H)
Weight	≈6KG

## VI. Hardware Diagram:

Unit: mm

